

# Image Fusion with Contrast Enhancement Using DWT & SVD

**ASHISHGOUD PURUSHOTHAM (M.Tech.)**

H.O.D., Department Of E.C.E., J.D.C.T., Indore

Email : ashishgoudp@gmail.com

**G.USHA RANI (M.Tech.)**

Assist. Prof., Department Of E.C.E., J.D.C.T., Indore

Email : usharanigodugu@gmail.com

**SAMIHA NAIK**

M.Tech. (perusing), E.C.E., J.D.C.T., Indore

Email : naiksamiha16031988@gmail.com

---

## ABSTRACT

Contrast is one of the important quality factors in image processing. Contrast is created by the difference in luminance reflected from two adjacent surfaces. In visual perception, contrast is determined by the difference in the colour and brightness of an object with other objects. If the contrast of an image is highly concentrated on a specific range, the information may be lost in those areas which are excessively and uniformly concentrated. This paper described a new contrast enhancement approach based on Discrete Wavelet Transform (DWT) and Singular Value Decomposition (SVD) that results in quality improvement of low contrast images. The input image is decomposed into four sub bands using DWT and obtain singular value matrix of the low-low sub band image and finally reconstructs the enhanced image by applying IDWT.

Key Words: Contrast enhancement, DWT, Image equalization, SVD, Wavelet thresholding

---

Date of Submission: April 18, 2015

Date of Acceptance: May 24, 2015

---

## I. INTRODUCTION

Due to imperfections of imaging devices (optical degradations, limited resolution of sensors) and instability of the observed scene (object motion, media disorder), acquired images are often blurred, noisy and may exhibit insufficient spatial and/or temporal resolution. Such images are not suitable for object detection and recognition. Image fusion<sup>[2]</sup> is a process of combining multiple input images of the same scene into a single fused image, which preserves relevant information and also retains the important features from each of the original images and makes it more suitable for human and machine perception. Reliable detection requires recovering the original image. If multiple images of the scene are available, this can be achieved by image fusion. The main condition for successful fusion is that "all" visible information in the input images should also appear visible in the fused image

Contrast and edge enhancement are frequently referred two of the most important issues in image processing. The problem is to optimize the contrast of an image in order to represent all the information in the input image. When we observe the objects, the clearest part we see firstly is edge and line. According to the composition of the edge and line, we can know the object structure. So in order to increase the contrast in an image, it results in better visualization and content rich information in a resultant image. So the fused image obtained by fusion process outcome in image quality enhancement and better apparition.

The image enhancement research can be broadly divided in to two domain; spatial and transform<sup>[1]</sup>. Out of these

two more investigation has been conducted in wavelet transform domain. This paper gives a new method that is based on DWT & SVD. The main motivation behind using SVD for quality improvement comes from the fact that  $\sum_A$  contains intensity information<sup>[4, 5]</sup> of particular image. SVD used to obtain the ration of the highest singular value of the created normalized matrix over a normalized input image. The use of SVD preserves maximum edges information so that the enhanced image looks better in contrast, brightness and edges.

## II. DISCRETE WAVELET TRANSFORM

The DWT<sup>[7]</sup> is one of the recent wavelet transform used in image processing. It is about the breaking up of a signal into shifted and scaled versions of the mother wavelet. DWT of image signals produces a non-redundant image representation, which provides better spatial and spectral localization of image information, compared with other multi scale representations. The DWT can be interpreted as signal decomposition in a set of independent, spatially oriented frequency channels. The signal S is passed through two complementary filters and emerges as two signals, approximation and Details. This is called decomposition or analysis.

The components can be assembled back into the original signal without loss of information. This process is called reconstruction or synthesis. The mathematical manipulation, which implies analysis and synthesis, is called discrete wavelet transform and inverse discrete wavelet transform.

A systematic block diagram of DWT filter banks of level-1 is shown in figure 1. This action splits the input image

into four sub band images which are known as LL, LH, HL, and HH. Then wavelet coefficient is modified by suitable thresholding function. Finally inverse wavelet transform is applied to obtain the reconstructed image. In wavelet based thresholding technique, thresholding function has major effect on quality of image<sup>[8]</sup>.

### III. SINGULAR VALUE DECOMPOSITION

SVD is a decomposition of a real or complex matrix with lots of helpful properties in image and signal processing. It is a numerical technique used to diagonalizable matrices. SVD is a method of decomposing correlated variables into a set of uncorrelated variables which is used to give improved representation of numerous relationships between the original data items<sup>[4, 9, 10]</sup>. Singular value decomposition (SVD)<sup>[11]</sup> of an image, which can be interpreted as a matrix is written as follows:  $A = U_A \Sigma_A V_A^T$  ... (1)

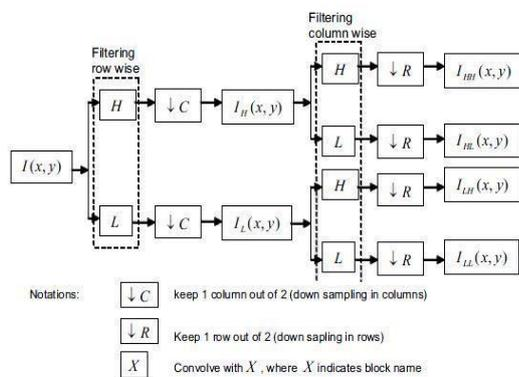

Fig. 1: Block Diagram Of DWT Filter Banks Of Level-1

where  $U_A$  and  $V_A$  are orthogonal square matrices known as hanger and aligner, respectively, and the  $\Sigma_A$  matrix contains the sorted singular values on its main diagonal. The idea of using SVD for image equalization comes from this fact that  $\Sigma_A$  contains the intensity information of a given image. Mainly SVD was used to deal with an illumination problem. The method uses the ratio of the largest singular value of the generated normalized matrix, with mean zero and variance of one, over a normalized image which can be calculated according to:

$$\xi = \frac{\max(\Sigma_N(\mu=0, var=1))}{\max(\Sigma_A)} \dots (2)$$

Where  $\Sigma_N(\mu=0, var=1)$  is the singular value matrix of the synthetic intensity matrix. This coefficient can be used to regenerate an equalized image using:

$$E_{equalized} A = U_A (\xi \Sigma_A) V_A^T \dots (3)$$

where  $E_{equalized} A$  is representing the equalized image  $A$ . This task is eliminating the illumination problem.

Singular value provides energy information of the image as well as knowledge of how energy is distributed<sup>[8]</sup>. For a smooth image the first few singular values will be

dominant while all others are less significant. In most of the cases the first singular value corresponds to mean of the image and closely relating to the spectral features while all other singular values provide detailed information of spatial content of the image and it relates to the textural features.

In this paper work DWT is applied to the input image and it decomposes into four sub band images. The frequency components of these sub band images cover all the frequency components of the original image. So, after IDWT enhanced

Image will be more effective, sharper and having a high quality contrast.

### IV. PROPOSED METHODOLOGY

The SVD contains illumination information in the image so that the conversion of the singular values will directly change illumination of the image and other information present in the image will remains same as before. The enlightenment information is surrounded in the LL sub band and edges are concentrated in other sub bands. So separating the high- frequency sub bands and applying the illumination improvement in LL sub band will protect the edge information from possible degradation and then application of IDWT for reconstruction of image will gives sharper image.

The mechanism of contrast enhancement can be attributed to thresholding of DWT component and scaling of singular values of LL coefficients. Since singular<sup>[8]</sup> values denote luminance of each image layer after decomposition, scaling of these values leads to variation of luminance of each layer and hence leads to overall contrast enhancement.

Figure 2 shows the flow chart for proposed method. Following steps are under taken to explain the main computational process of the proposed method. In the very first step, one input image is taken for the analysis. Image is equalizing using general histogram equalization technique. After equalization, compute the discrete wavelet transform. DWT of an image decomposed four sub band images referred to as (LL, LH, HL, and HH). Calculate  $U$ ,  $\Sigma$  and  $V$  for LL sub band image. Calculate  $\zeta$  using the equation following  $\zeta = \max(\Sigma_{LLA}) / \max(\Sigma_{LLA})$ . Then calculate the new  $\Sigma$  and reconstruct the new LL image.

Same procedure is applied on second input image. Now apply select maximum rule to get final sub band images. Finally, each resultant sub band images are combined using IDWT to get final fused image.

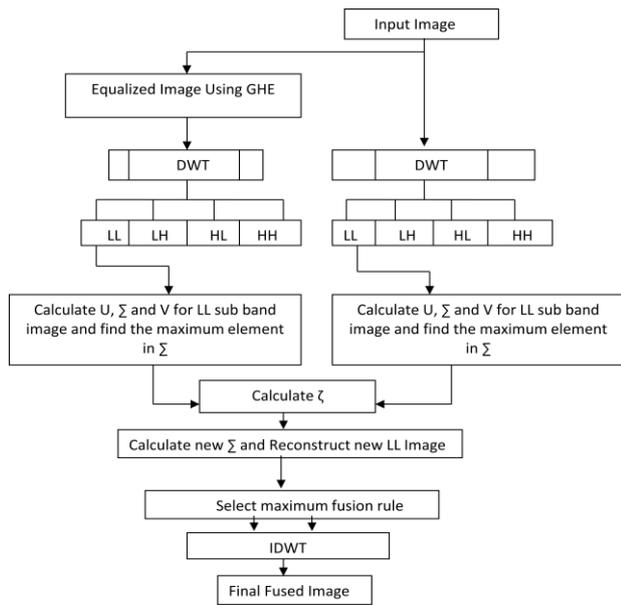

Fig. 2: Flow Chart Of Proposed Method

## V. RESULT & DISCUSSION

In this section, performance of proposed method using SVD & DWT is evaluated by considering fidelity assessment parameters like mean, standard deviation, PSNR, MSE.

Mean is the average of all intensity value and higher mean denotes the good quality of image. Standard deviation gives the average contrast of the image. Higher standard deviation indicates good contrast of fused image. The MSE represent the cumulative squared error between the original image and reconstructed image. The lower the value of MSE, the error may be lower. PSNR used for quality measurement ratio between original image and reconstructed image. The higher the PSNR, the better the quality of the reconstructed image.



Fig. 3: (a) Input image 1 (b) Input image 2 (c) Fused image using DWT Approach (d) Fused Image using Proposed Approach

## VI. CONCLUSION

In this paper, an improved method for quality enhancement is proposed. This paper presents a contrast enhancement method for low resolution image using DWT-SVD. From

figure 3 we can observe that quality of the fused image using proposed method is much better than the DWT method. Again from table 1, all the performance parameters are high for proposed method except MSE for which we require lower value for lower error in fused image. So we can conclude that combination of SVD-DWT gives better resultant fused image.

## REFERENCES

- [1]. Gonzalez RC, woods RE, Digital image processing, 2<sup>nd</sup> edition, Singapore; Pearson Prentice-Hall;2002.
- [2]. Shih-Gu Huang “Wavelet for Image Fusion”, National Taiwan University.
- [3]. Mallat G. Theory for multi-resolution signal decomposition; the wavelet representation , IEEE Trans pattern Anal Mach Intell 1989; 2(7);674-94.
- [4]. M. Arfan Jaffar” “ Ayyaz Hussain” “BLOCK-BASED PIXEL LEVEL MULTI-FOCUS IMAGE FUSION USING PARTICLE SWARM OPTIMIZATION” International Journal of Innovative Computing, Information and Control ISSN 1349-4198 Volume 7, Number 7(A), July 2011.
- [5]. Bhandari A.K. , Gadde M., Kumar A, Singh G.K., Comparative analysis of different wavelet filters for low contrast and brightness enhancement of multi spectral remote sensing images. In: Proceedings of IEEE international conference on machine vision and image processing, p.81-6;2012.
- [6]. Kroeger G.C., Geologic remote sensing and multi spectral image processing, 1995.
- [7]. Ling Y. Ehlers M, Usery EL, Madden M. FFT-enhanced IHS transform methods for fusing high resolution satellite images. ISPRS J Photogr Remote Sens 2007;61(6):381-92.
- [8]. A.K.Bhandari, " Cuckoo search algorithm based satellite image contrast and brightness enhancement using DWT-SVD", ISA Transactions, volume 53, Issue 4, July 2014, Pages 1286-1296.
- [9]. Kumar A., Bhandari AK, Padhy PK. Improved normalised difference vegetation index method based on discrete cosine transform and singular value decomposition for satellite image processing. IET signal process 2012;6(7);617-25.
- [10]. Sverdllov A,Dexter S, Eskicioglu AM. Robust DCT-SVD domain image water marking for copy right protection: embedding data in all frequencies. In: Proceedings of the multimedia and security workshop, ACM Press;2004. p.66-174.
- [11]. Sivakumar, K.Mageswary, Dr.M.Rajaram, “Image Contrast Enhancement Using Singular Value Decomposition for Grey Scale Images”, Proceedings of 2011 International Conference on Signal Processing, Communication, Computing and Networking Technologies, (ICSCCN 2011).